

ORDINANCE NO. 13-18

TO AMEND CERTAIN PORTIONS OF THE UNIFIED ZONING ORDINANCE OF TIPPECANOE COUNTY, INDIANA, DESIGNATING THE TIME WHEN THE SAME SHALL TAKE EFFECT.

BE IT ORDAINED BY THE COMMON COUNCIL OF THE CITY OF WEST LAFAYETTE, INDIANA, THAT ORDINANCE NO. 32-97 IS HEREBY AMENDED AS FOLLOWS:

Section 1: Amend the list in **UZO Section 4-6-18 OFF-STREET LOADING** as shown below:

(d) Except in CB and CBW **zones** where this subsection does not apply, the **Administrative Officer** shall determine the height of the noise barrier structure and how off-street **loading berths** are to be screened from adjacent **residential zones** or **uses**, employing one or more of the following means:

- (7) a dense planting of **evergreen** plant materials to the satisfaction of the **Administrative Officer** and a noise barrier structure of a minimum of 8' in height; or
- (8) a dense planting of mixed **evergreen** and **deciduous** plant materials to the satisfaction of the **Administrative Officer** and a noise barrier structure of a minimum of 8' in height.

Section 2: Change **UZO Section 4-9-1 INTENT** of the Bufferyard and other bufferyard requirements, by amending it as shown below:

Standard plant units shall conform to illustrations in Appendix E-1 or their functional equivalent as approved by the **Administrative Officer**.

Section 3: Add to the list in **UZO Section 4-9-2 BUFFERYARD REQUIREMENTS** as shown below:

(f) The requirement of a **bufferyard** along a common property line where the property line serves as the boundary between **zones** and properties on either side of the line are owned by the same entity or individual shall be determined by the **Administrative Officer**. If the **bufferyard** is required, then the type shall also be determined by the **Administrative Officer**.

(g) Required **bufferyards** shall be located outside of any existing or platted utility or drainage easement.

(h) Plant species shall be selected from the approved tree lists available on the City of West Lafayette's official website except for property in Lafayette which shall use its own approved tree list.

Section 4: Change **UZO 4-9-3-a TYPE OF BUFFERYARD REQUIRED ALONG A LOT LINE SEPARATING A ZONE UNDERGOING DEVELOPMENT OR REDEVELOPMENT AND AN ABUTTING ZONE** by making the following adjustments:

ZONE UNDERGOING DEVELOPMENT OR REDEVELOPMENT	ABUTTING ZONE											
	R1 R2U MRU Zones (Amend 27, 60, 69 & 71)	R1A R3	R1B R3W	R1U R4W	R1Z RE & the residential portion of PD	R2 PDRS	OR	NB MR GB HB OR	I1	I2	I3	A AA AW FP
R1 R1A R1B R1Z R2 R3 R3W R4W RE (Am 27)	---						A	C ²	B	B	C	---
OR	A						---	B	---	---	B	---
NB MR GB HB OR	C ²						B	---	A	A	A	B
I1	B						---	A	---	---	A	B ¹
I2	C						B	A	---	---	A	C ¹
I3	C						B	A	A	A	---	C ¹
ZONE IN WHICH MHP/MHC OR RVP/C IS BEING DEVELOPED												
MHP/MHC: R3 A RVP/C: HB A AW FP	C						A	C	B	B	C	A
ZONE IN WHICH SELF-STORAGE WAREHOUSE IS BEING DEVELOPED (Amend 5,92)												
NB GB I1 I2 I3	C						A	A	A	---	---	A

Section 5: Rename, eliminate and change parts of **UZO Section 4-9-3-b NUMBER OF REQUIRED STANDARD PLANT UNITS AND BUFFERYARD WIDTHS FOR BUFFERYARDS, TYPE A-C** as shown below:

4-9-3-b BUFFERYARD WIDTHS, TYPES A-C:

TYPE OF BUFFERYARD	NUMBER OF STANDARD PLANT UNITS PER 150 LINEAR FEET	BUFFERYARD WIDTH
A, B	2	15'-20'
B	3	20'
C	4	20'-30'

Section 6: Replace **UZO Section 4-9-4-a STANDARD PLANT UNITS** by amending it as shown below:

- (a) The drawing in Appendix E-1 shows the requirements for Type A, Type B and Type C **bufferyards** using **standard plant units**.

Section 7: Remove **UZO Section 4-9-4-b STANDARD PLANT UNITS**

Section 8: Renumber **UZO Section 4-9-4-c STANDARD PLANT UNITS** to 4-9-4-b.

Section 9: Replace **UZO Section 4-9-5-d RESPONSIBILITIES FOR BUFFERYARDS** as shown below:

(d) The property owner or developer shall provide **bufferyard** plans prepared by a registered landscape architect to the **Administrative Officer** for approval.

Section 10: Replace **UZO appendix E-1: STANDARD PLANT UNITS** as shown below:

APPENDIX E-1: STANDARD PLANT UNITS

TYPE A: three **evergreen trees**, a minimum of 8' tall, planted 10' apart, center to center and six **deciduous shrubs** a minimum of 3' high planted 5' apart, center to center.

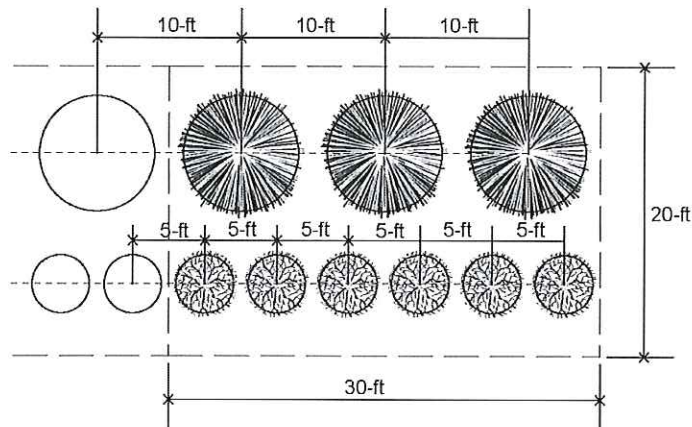

TYPE B: three **evergreen trees**, a minimum of 8' tall, planted 10' apart, center to center and five **evergreen shrubs** a minimum of 3' high planted 6' apart, center to center.

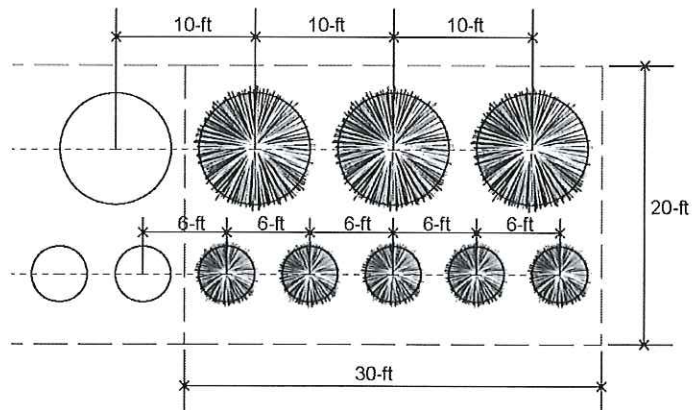

TYPE C: two staggered rows of three **evergreen trees** a minimum of 8' tall planted 10' apart, center to center.

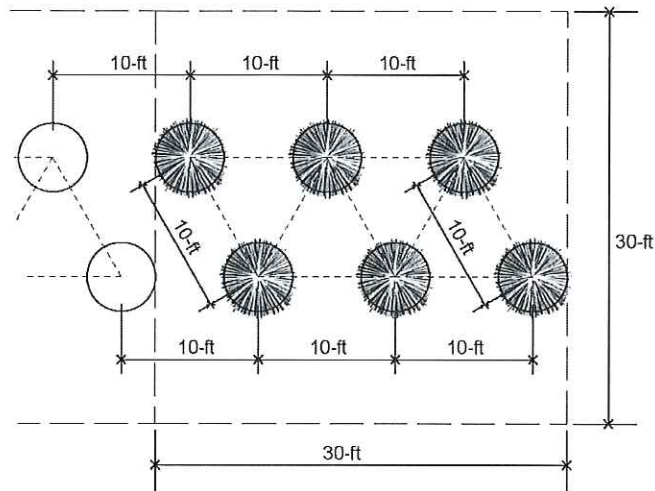

Section 11: Add the footnote in **UZO appendix E-1: STANDARD PLANT UNITS** as shown below:

E-1-1 Evergreen trees may be reduced in height by 2' if the **bufferyard** features a 3' high berm.

Section 12: Remove **UZO appendix E-2: ILLUSTRATION OF BUFFERYARDS -- TYPES A, B, and C.**

This ordinance shall be in full force and effect from and after its passage.

INTRODUCED ON FIRST READING ON THE 4 DAY OF June, 2018.

MOTION TO ADOPT MADE BY COUNCILOR Keen, AND SECONDED BY COUNCILOR DeBoer.

DULY ORDAINED, PASSED, AND ADOPTED BY THE COMMON COUNCIL OF THE CITY OF WEST LAFAYETTE, INDIANA, ON THE 4 DAY OF June, 2018, HAVING BEEN PASSED BY A VOTE OF 8 IN FAVOR AND 0 OPPOSED, THE ROLL CALL VOTE BEING:

	AYE	NAY	ABSENT	ABSTAIN
Bunder	✓			
DeBoer	✓			
Dietrich	✓			
Jones	✓			
Keen	✓			
Leverenz	✓			
Sanders			✓	
Thomas	✓			
Wang	✓			

 Peter Bunder, Presiding Officer

Attest:

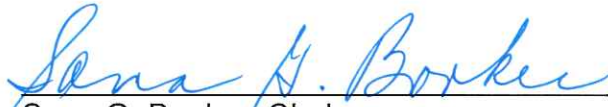
 Sana G. Booker, Clerk

PRESENTED BY ME TO THE MAYOR OF THE CITY OF WEST LAFAYETTE, INDIANA
 ON THE 5 DAY OF June, 2018.

 Sana G. Booker, Clerk

THIS ORDINANCE APPROVED AND SIGNED BY ME ON THE 7 DAY OF
June, 2018.

 John R. Dennis, Mayor

Attest:

 Sana G. Booker, Clerk